

ROMP-5

Strapping Machine

MOSCA®
EAM MOSCA



- Cycle Speeds up to 50/Minute
- Simplified, Durable Design
- Superior Reliability

Innovative Strapping Systems

ROMP-5

Standard Features

Mosca strapping systems are renowned for superior performance in a broad range of applications. The ROMP5 is an operator cycled strapping system built around Mosca's DC brushless direct drive technology. Its combination of convenience, speed and reliability make it the superior solution for production driven users who want top performance from their production process.

- Direct drive sealer.
- Robust construction.
- Sliding drawer, side loading coil dispenser with push button coil threading for fast and convenient coil changes.
- Interlocked, hinged, removable tabletop for fast, convenient access to the sealer for cleaning or troubleshooting.
- Forms and ejects strap loops if accidentally cycled without a bundle. Avoids jamming.
- Precision single piece strap track for positive strap control and exceptional feed reliability with PP strap from 5 to 12mm wide.
- Control panel and footbar can be set for either right or left hand operation. Left hand standard.
- Two locking swivel casters and two fixed casters for easy mobility and positioning.
- Cycle speed of up to 50 per minute via footbar or photo-eye activation.

EAM-Mosca is a high performance systems company focused on the sale of superior strapping equipment whose performance is enhanced through the use of Mosca strapping and support:

- Our strapping is made from top grade materials using process parameters designed to minimize dimensional variation, dust creation and splitting while optimizing seal strength.
- We are committed to excellent customer service with typically next day strap and parts service.
- Professional technical support located throughout North America and Mexico with no-charge phone support available during normal business hours. Factory or on-site training is available for your technical and maintenance staff.



Technical Data

- Production Rate:** Up to 50 Bundles/Minute
Strapping: 5mm, 6mm, 8mm, 9mm and 12mm Machine Grade PPY
Track Size: See chart. Custom track sizes available
Electrical: 110V 60 Hz, .5 KVA
Air Requirements: No requirement for standard machine. 10 CFM @87 psi with press option.
Table: Standard machine has stainless steel table top
Table Height: Standard Frame: 32.25" - 36.5" (820mm - 925mm); Low Frame: 28.75" - 32.85" (730 - 835mm) Available upon request.
Strap Tension: DC Motor Controlled, infinitely adjustable up to 80 lbs.
Strap Seal: Heat-seal, electronic temperature controlled
Machine Color: Mosca Blue RAL 5010
Machine Shipping Weight: Depending upon model, approx. 530 Lbs. on pallet
Casters: Heavy-duty, two swivel-lock and two fixed
Options:
- Pneumatic Press (reduces DIM B by 100 mm)
 - Cylindrical Roller Table Top
 - Roller Ball Table Top
 - Photo-eye activation

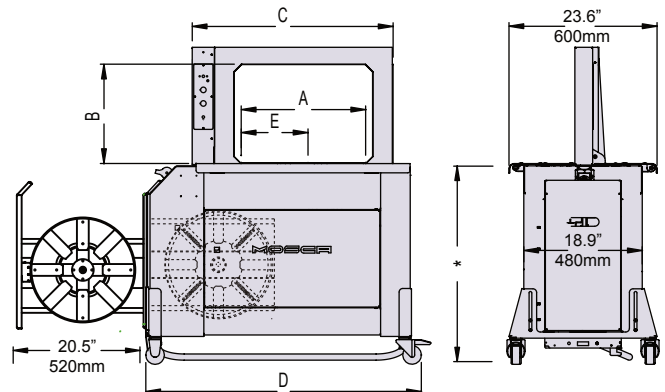

* Standard Frame: 32.25" - 36.5" (820mm - 925mm); Low Frame: 28.75" - 32.85" (730 - 835mm)

Standard Track Sizes	DIM				
	A	B	C	D	E
	mm	mm	mm	mm	mm
ROMP5-50/4	500	400	815	1170	250
ROMP5-60/5	600	500	915	1370	300
ROMP5-80/4	800	400	1115	1370	400
ROMP5-80/6	800	600	1115	1370	400
ROMP5-100/8	1000	800	1315	1570	400



PO Box 425
 Baldwinsville, NY 13027
 800 356-8964 315 638-9431
 FAX 315 638-9433
 www.typac.net
 info@typac.com